

# Upgrading to a RBK Control Box



**ShopBot Tools, Inc.**  
3333-B Industrial Drive,  
Durham NC 27704  
ShopBotTools.com

**Technical Support**  
support @shopbottools.com  
1-888-680-4466

## Revision History

Date:	ECO:	Change:	Changed By:
2015 10 27		Changed p. 4 diagram caption from 2/PX to 3/PY per 10/26 email from technical support	M. Cummings

## Table of Contents

Connecting Existing Motor Cables .....	4
Re-connecting Existing peripherals .....	6
Connect the Cables from the Proximity Switch and Z-zero Plate .....	7

## Connecting Existing Motor Cables

If upgrading the ShopBot control system to the RBK control box, it is necessary to swap out the existing control box. Remove the control box and unplug all motor cables, prox switches, stops, and Zzero plates from the system. Mark the motor cables (if not already) so that these cables will be easy to identify later. ***It may be necessary to mount the new control box closer to the previous control box location due to the pre-set cable lengths of the assembled machine.***

Remove the PRSstandard control board by removing the (6-8) screws that mount the control board to the RBK drives.

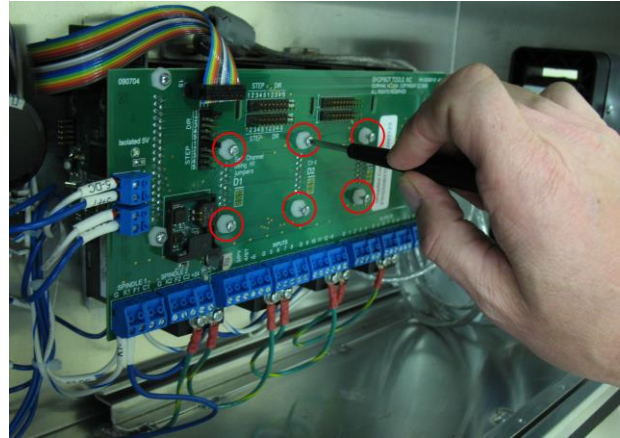

Remove the 2 pin terminal block from the 5V+ and the 24V+ positions on the left side of the control board.

The 4 pin terminal block in the Spindle 1 position on the lower left corner will also need to be disconnected before the control board can be removed.

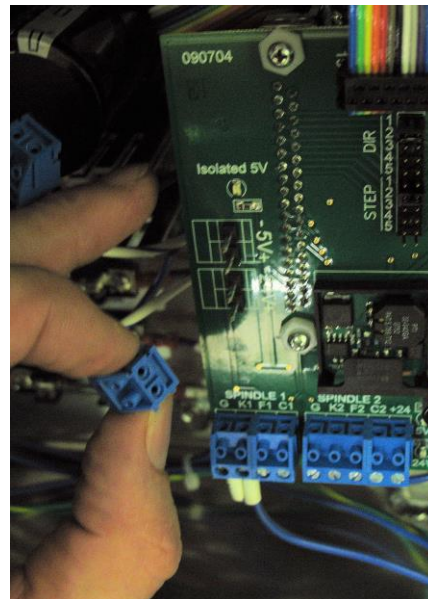

Remove the RBK control board to reveal the drivers. The drivers are ordered from left to right to correspond with the motor cables: X1, X2, Y, Z (A & B if purchased).

***The number of drivers represented here may differ based on the ShopBot PRSstandard required for your size model at time of purchase.***

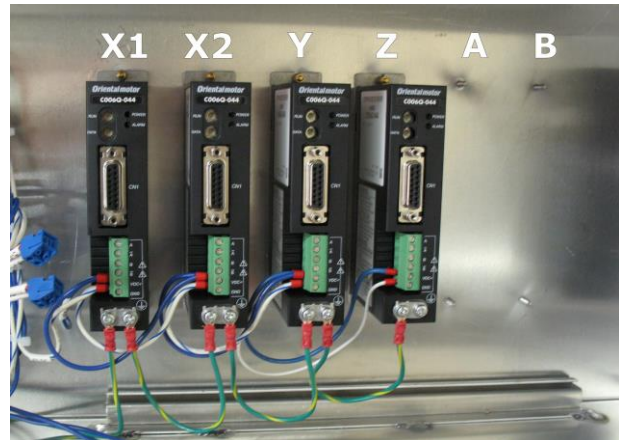

Using a Wago tool, remove the wires from a motor cable.

Open the Roxtec wire management system, on the right side of the control box, and route the motor cables to the drivers.

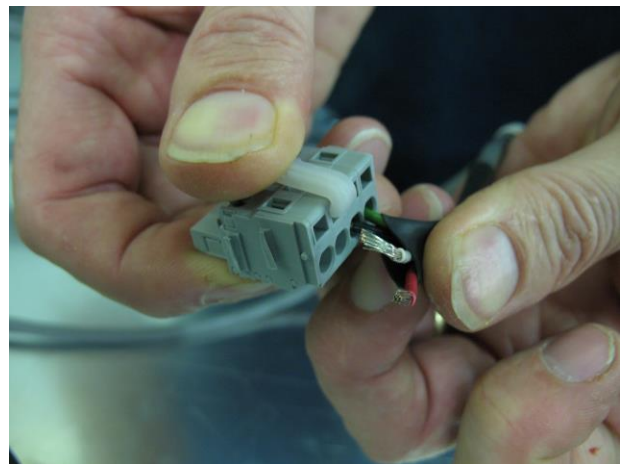

Depending on which motor cable the Wago plug was removed from, find the corresponding driver and wire the motor cable into the green terminal block. Wire from top to bottom.

**X1 & Y cables** should be wired Red, White, Green, and Black .

**X2 & Z cables** should be wired Red, White, Black, and Green.

***The Green and Black reverse motor direction.***

Repeat for wiring for remaining motor cables.





Carefully replace the RBK control board making sure that the connections on the board seat back into the drivers, then replace the (6-8) mounting screws.

**Caution: Pay close attention when re-connecting the 5V+ and 24V+ 2 pin terminal blocks to the control board. Mis-wiring these two can damage the communication card on the board (the wires are marked 5V & 24V).**

Re-connect the 4 pin terminal block to the spindle 1 position on the lower left corner of the board.

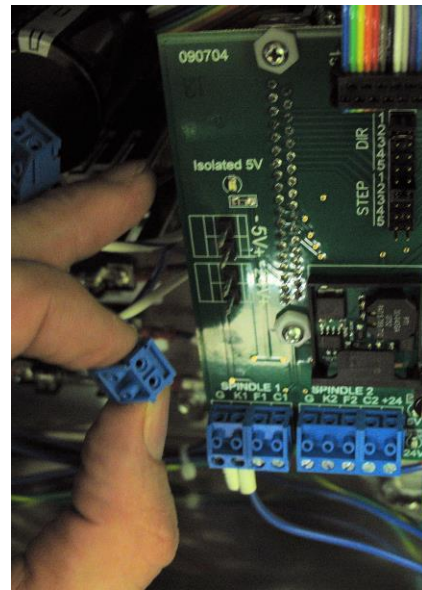

## Re-connecting Existing peripherals

On the left most third of the RBK Standard control board is the location where the remote stop switch, X&Y prox switches, and the Z-zero plate will be connected, using the wiring diagram below, wire in these peripherals. **Note: some of the terminal positions may share more than one wire. The terminal blocks can be removed to make wire insertion easier.**

Route the remote stop switch cable into the control box and connect the Red wire to G (ground) and the black to 4/ST (input 4). (Optional on older machines)

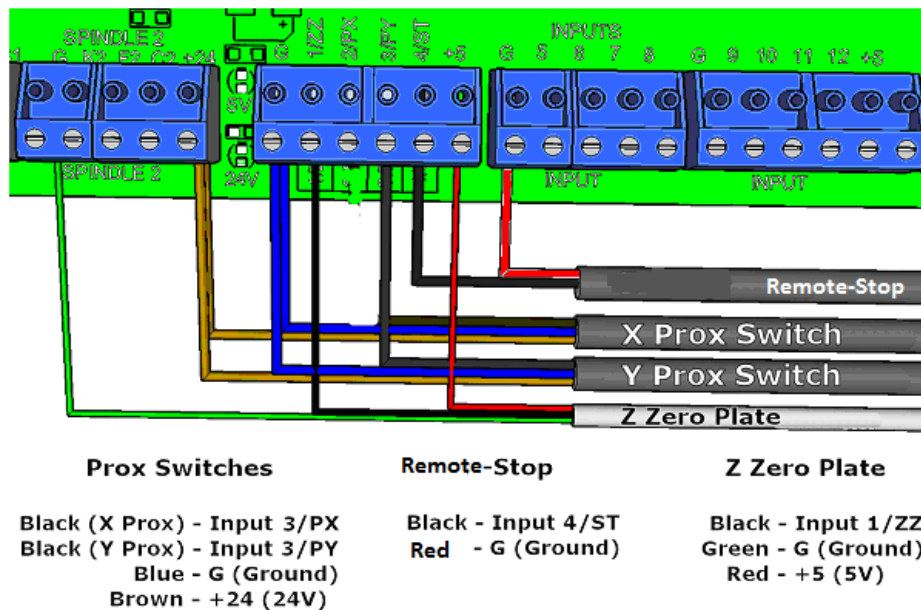

## Connect the Cables from the Proximity Switch and Z-zero Plate

Route the Proximity Switch cables inside the RBK Standard control box. Take the cables for both the X-axis and Y-axis and connect the black wires into 3/PY (Input 3) on the same blue terminal block on the control board. The blue wires from both of the switches are placed in G (ground). The brown wires from both of the switches will be placed in the +24 (24V) position of the terminal block.

Now connect the Z-zero plate. The black wire goes in the 1/ZZ (Input 1) terminal and the green wire goes into a G (ground) terminal; any G position may be used since they are all a common ground. The red wire goes to +5 (5V), (it is only used by the Digitizing Probe).