

Control Box Wiring

For PRSalpha Tools



Table of Contents

Introduction	4
Installation	4
Powering the PRSalpha Control Box	4
Exploring the PRSalpha Control Box	5
Inside the PRSalpha Control Box	5
Connect the Cabling.....	6
Connect Grey VFD Cable	7
Attach Fan to HSD Spindle with Plug.....	7
Attach Fan to 24V Power Supply.....	8
Connect Power Cable from VFD to Spindle	8
Plug Motor Cables into Drivers.....	8
Emergency Stop Switch and 3-Button Pendant.....	9
Proximity Switch and Z-Zero Plate.....	10
Using the Cable Entry.....	10

Introduction

The control box is typically installed on the front left side of the machine. This document covers hooking up the motors, proximity switches, VFD, and remote button pendants inside of the control box.

Installation and Mounting

Please refer to the PRS Assembly Guide included with the tool documentation, and located in the **Support** area of our website under the *Documentation* heading before, before continuing with this document.

Powering the PRSalpha Control Box



The power to the PRSalpha control box should be wired into a fused disconnect by a licensed electrician familiar with industrial equipment.

The power requirements for the PRSalpha control box and router/spindle vary according to configuration. The table below outlines some of the power requirements for different configurations. The schematic for the specific control box configuration, including the power requirements, can be found inside the door of the PRSalpha control box.

Note: Since the power requirements for a Porter Cable router and for a spindle vary, different components are installed in the PRSalpha control box depending on which is used. This is NOT user configurable; control box specifications are determined at the time these components were ordered. If different power requirements are necessary, please contact customer support.

US Standard, 60Hz PRSalpha Control Box and Porter Cable router: 220V single phase, 20A circuit. The two legs will be split into two 110V circuits inside the PRSalpha control box; one for the PRSalpha control box, and one for the router.

PRSalpha Control Box and Spindle (3 phase): 110V 15A circuit for the PRSalpha control box plus 230V 3 phase circuit for the spindle. Specifications for full-load current of the different models of spindle are provided with the control box.

PRSalpha Control Box and Spindle (single phase): 110V 15A circuit for the control box plus 220V single phase circuit for the spindle. Specifications for full-load current of the different models of spindle are provided with the control box.

PRSalpha Control Box and two Spindles: 110V 15A circuit for the PRSalpha control box plus the appropriate 220V or 230V circuit for the spindles.

European Standard, 50Hz PRSalpha Control Box and 230V/50Hz Porter Cable router (single speed): 230V single phase line with 10A circuit for the PRSalpha control box plus 15A/230V single phase line for the Porter Cable router.

PRSalpha Control Box and Spindle (3 phase): 230V single phase, 10A circuit for the PRSalpha control box plus 380V 3 phase circuit for the spindle. Specifications for full-load current of the different models of spindle are provided with the control box.

Exploring the PRSalpha Control Box



WARNING: Disconnect electrical power to the PRSalpha control box prior to this step! Failure to do so can cause personal and/or equipment damage.



After the electrician has hooked up the PRSalpha control box, open the side of the box with a flathead screwdriver (quarter turn locks). For safety reasons, the door is designed to lock open or closed unless the main power disconnect is turned off.

NOTE: The PRSalpha control box has an interlock for the router/spindle. This interlock allows for the power to the router/spindle to be disconnected without interrupting power to the machine. This adds additional safety for manual tool changes during a cut file.

Inside the PRSalpha Control Box

NOTE: Not all control boxes will be the same as pictured, depending on the specific configuration. If unable to follow the steps in this guide, contact the ShopBot support team for further assistance (picture found on following page).

The contactors, located at the top-right of the control box and #6 in the diagram on the following page, are the large relays that control power to the cutting head and drive motors. They are controlled by the emergency stops, the software, and by relays on the control board. The size of the contactor may vary with the power requirements of the device it is powering. Additional contactors for additional devices (i.e. a second router or spindle cutting head) are added to the left of the standard contactors.

The fuses in the control box (US 60Hz power) are dependent upon the setup. For a complete listing of the fuses used on a specific tool, refer to the power diagram included in the door of the control box.

The fused disconnect should protect the control box, if power is lost to all parts of the control box, check the fuses and replace them with identical fuses if necessary.

Note! Before connecting the cabling, ensure the gasket shown in the picture to the right is installed on the opening on the side of the control box.



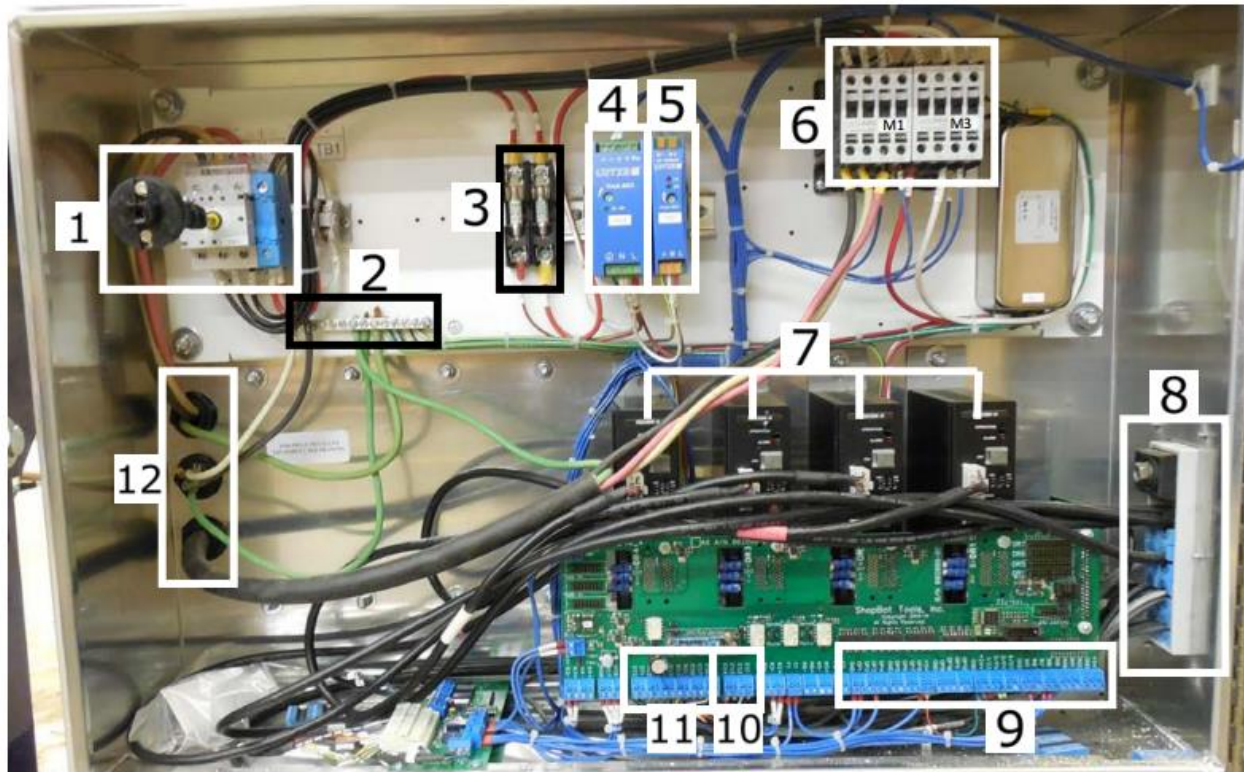

- | | | |
|----------------------|--------------------|---------------------------|
| 1. Disconnect switch | 5. 5V power supply | 9. Inputs/Output |
| 2. Grounding strip | 6. Contactors | 10. Emergency stop switch |
| 3. Fuses | 7. Motor drivers | 11. Three button pendant |
| 4. 24V power supply | 8. Cable Entry | 12. Cord grips |

Connect the Cabling

Run power from the ShopBot control box to the VFD.

Power to the VFD must be connected to the proper contactor in the ShopBot control box. This is necessary for the safety systems to work correctly if the emergency stop button is pressed. The VFD supplied by ShopBot will have the power cable pre-installed at the factory.

WARNING: Disconnect electrical power to the control box. Failure to do so can cause personal and/or equipment damage.

Run the black cable from the VFD to the vacant cord grip in the bottom of the control box. Insert the cable from the VFD into the cord grip, pushing enough wire into the control box to reach the spindle contactor(s) and the grounding strip.

Connect to contactor M1 for a single spindle and contactor M5 for a second spindle. Refer to the Control Diagram included in the door of the ShopBot control box to locate the correct contactors.

Connect the **green** wire from the VFD power cable to the ground bus bar, located under the main disconnect in the control box.

Connect the line conductors from the VFD to the proper contactor using the following terminals:

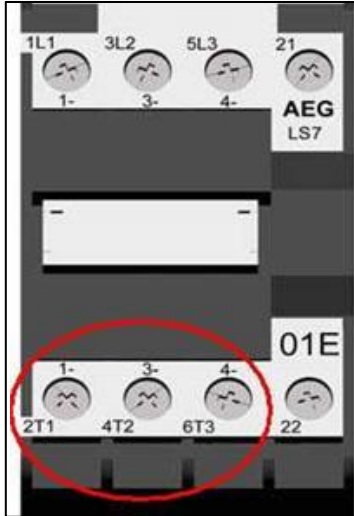

3 Phase Spindles	Single Phase Spindles
2T1 – Black Wire	2T1 – Black Wire
4T2 - White Wire	4T2 -White Wire
6T3 – Red Wire	
Ground – Green Wire	Ground – Green Wire

Tighten the cord grip after installing the wiring to secure it.



Note: If installing an ATC, stop here and refer to the ATC electrical installation manual now.

Connect Grey VFD Cable

The VFD logic cable should be a grey sheathed cable with three wires within – black, white and red (red clipped back). If there is a green wire instead of a white wire, consider the green wire as the white.

Run the grey cable from the VFD to the control box and pass the cable through the cable access on the right side of the box.

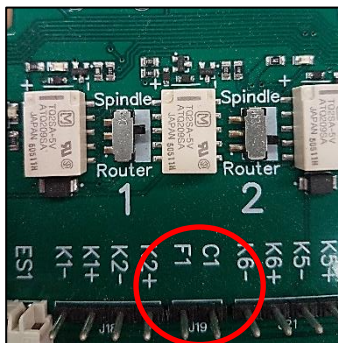

Connect the black wire and the white wire to the C1 and F1 terminals on the control board. The color order does not matter here.

Take a moment to ensure that the dip switches (above the C1 and F1 terminals) for the cutting heads are also set correctly - the up position is for a spindle and the down position for a router.



Attach Fan to HSD Spindle with Plug

Attach the fan connection plug on the (36ft) gray cable to the front face of the HSD spindle. Tighten the fan connection plug screw on the front now.

Attach Fan to 24V Power Supply

The PRSAlpha comes with a 24V power supply already installed in the control box.

If needed, strip back about ¼” of insulation from the red and black wires at the loose end of the cable from the fan connection plug.

Route the cable inside the control box and connect the red wire to the (+) and the black wire to the (-) on the top of the power supply (see picture to the right).



Connect Power Cable from VFD to Spindle

Plug the connector of the orange power cable into the HSD spindle power plug and depress the metal clip until it snaps into place.

Later, when powering on the control box, the fan should power up and start turning as soon as the control box is powered on.

Plug Motor Cables into Drivers

Run the motor cables through the cable routine opening and plug them into the black drivers (these are the black boxes arrayed horizontally in the control box - #7 in the open PRSAlpha control box illustration shown earlier).

The white plug fits the white receptacle on the driver in only one way. Make sure it is aligned correctly and fully seated.

The order of the motor drivers, starting from the entry point of the cables (right to left) is as follows:

- The X1 motor cable (red tape labelled X1) goes to the farthest right driver and X2 (red tape labelled X2) goes to the second farthest driver from the right.
- The Y motor cable (blue tape) should be plugged into the 3rd driver from the right.
- The Z motor cable (white tape) should be plugged into the 4th driver from the right.
- Additional motors (2nd Z axis, indexer, etc.) would be plugged into any additional drivers to the left of the four standard drivers. Refer to the documentation for this accessory for more information.

Emergency Stop Switch and 3-Button Pendant



The 3-button pendant and emergency stop button are bundled together for shipping. Both must be attached in order for the buttons and control box to function.

The 3-button pendant allows the reset, start and extra emergency stop buttons to be placed in a convenient and safe location for the operator. It has been prewired so hooking it up is as easy as possible, all the install should entail is plugging the block into the corresponding control board locations.

The separate emergency stop also plugs into a fitted block next to the 3-button pendant. Power for the router/spindle is

routed through the control box safety controls so that activating an emergency stop by hitting the RED BUTTON will stop the movement of the carriages and power down the router/spindle.

NOTE: Without the emergency stop connected, Input #4 will flash on the control software and the ShopBot control software will not allow the ShopBot to move.

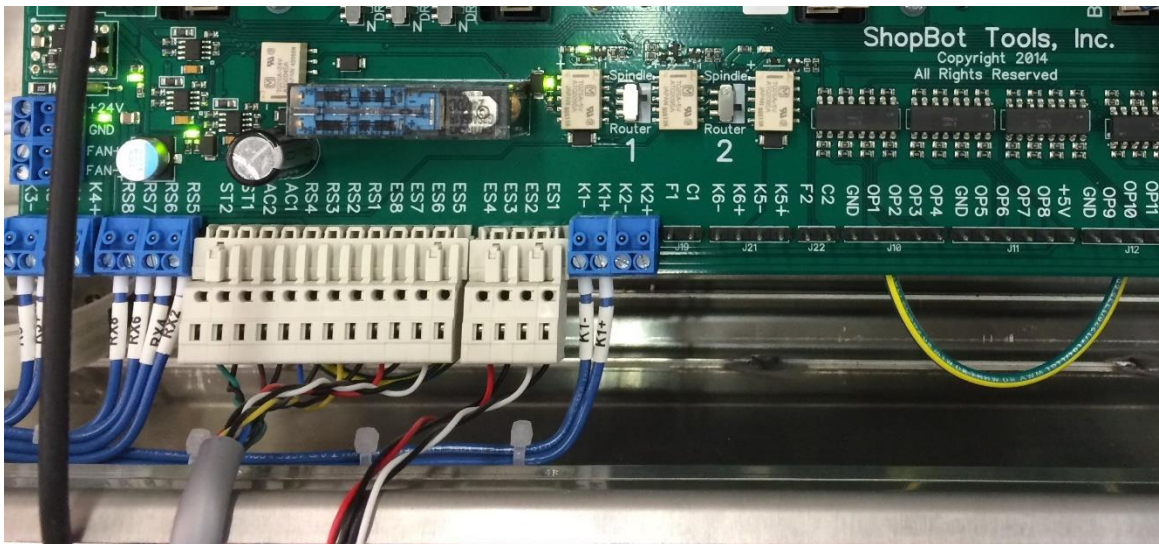
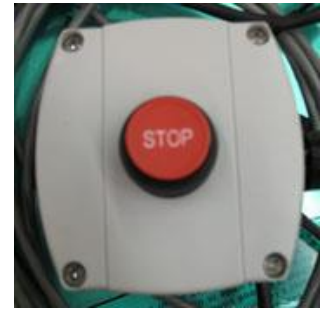

Route the 3-button pendant cable and emergency stop cables through the side of the control box and plug the white connector into the corresponding white connector on the control board.

Proximity Switch and Z-Zero Plate

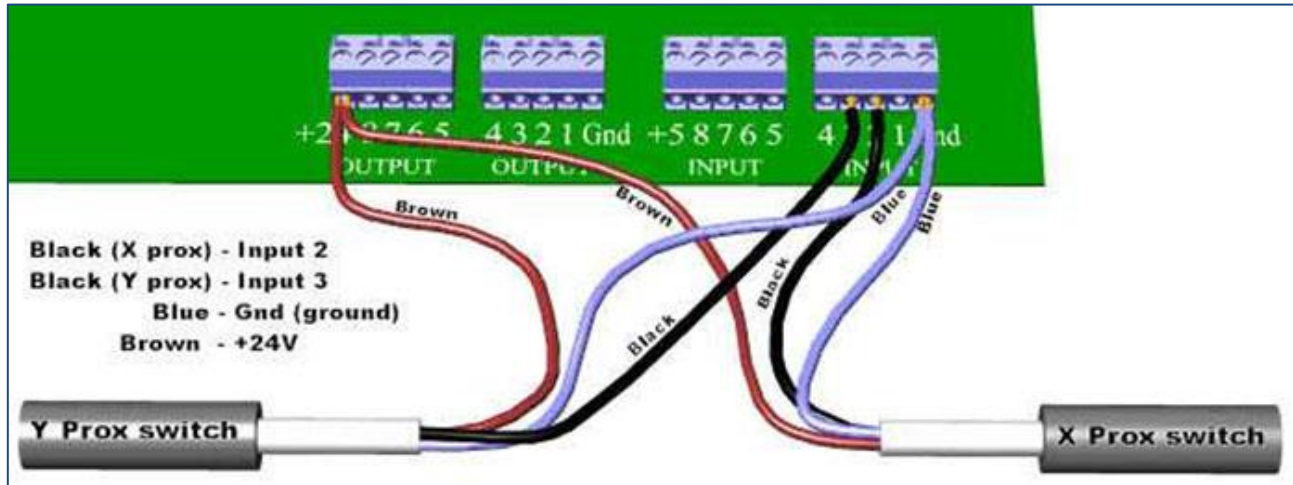

Run proximity switch and Z-zero plate cables through the side cable entry into the control box. Install the black wire of the X-axis proximity switch cable into input 2 on the blue terminal block on the control board. Install the black wire of the Y-axis proximity switch cable into input 3 on the same blue terminal block. Install the green or white wires from both switches into the GND (ground) terminal position. And install the red wires from both switches into the +24V terminal block position. Note that the terminal blocks can be removed to make wire insertion easier.

When the control box is powered up, a red LED in the body of the proximity switch will come on and stay lit until it is triggered by coming near a target.

The black wire for the Z-zero plate goes into the input #1 terminal position and the green wire goes into a ground terminal (Gnd). The red wire goes to the +5V terminal position (but it is only used by powered accessories like the digitizing probe).

Connect the USB cable into the small controller card (if not already connected) and plug the longer 10ft cable supplied by ShopBot into this connector and run the longer cable through the cable fixture. **Do not plug the USB cable into the computer at this point.**



WARNING: Ensure power is turned OFF before proceeding.

Using the Cable entry

The cable entry should already be installed on the control box, if it is not, the following are the steps for installation.

Once all of the cables have been attached inside the control box, run the cables through the modules and tighten the fixture to keep dust out of the control box.

The cable entry gives all wires a tight strain relief and will seal the control box against dust and debris. The steps on the following page is the manufacturer's suggested installation procedure.

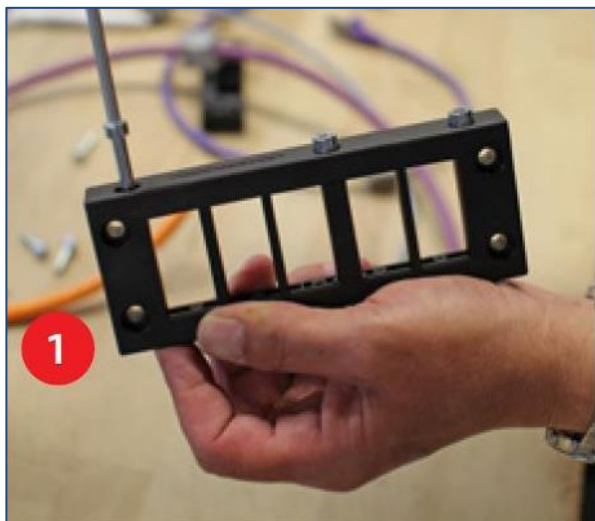

Loosen the screws of the frame.

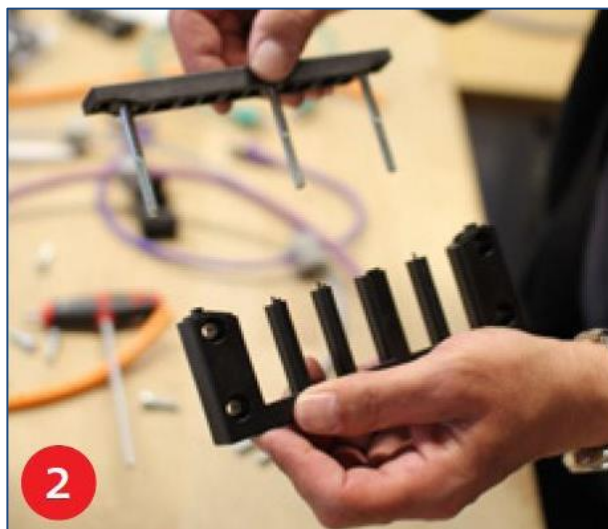

Remove the cover strip

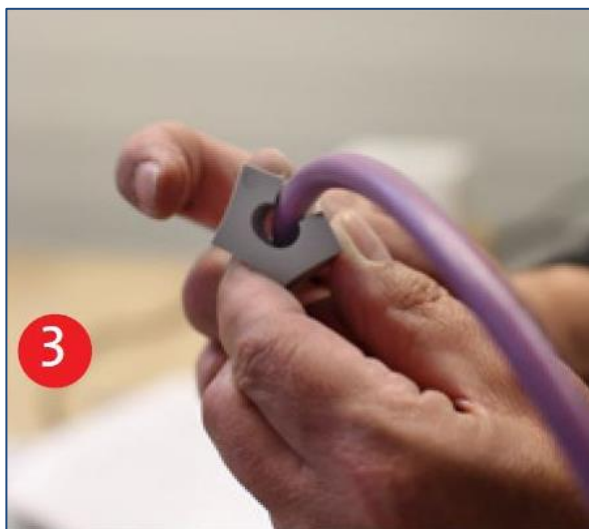

Equip the corresponding KT grommet with the cable.

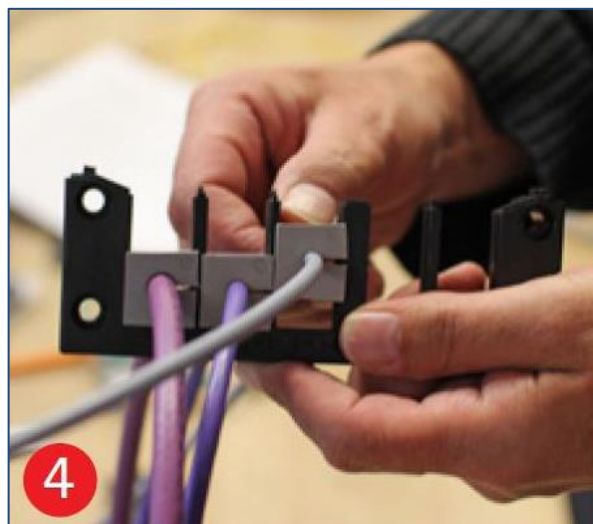

Slide the inserts into the frame. It must be ensured that the flat side of the grommets in the lower row are pointing to the open side of the frame half (flat sides pointing upwards).

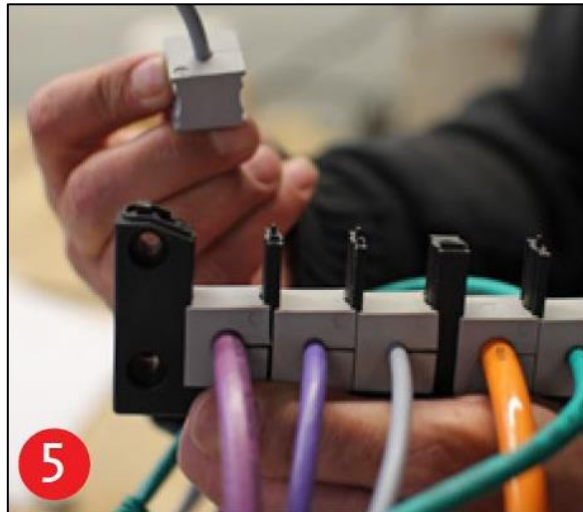

The flat side of the grommets in the upper row to point downwards so that all flat sides rest on each other.

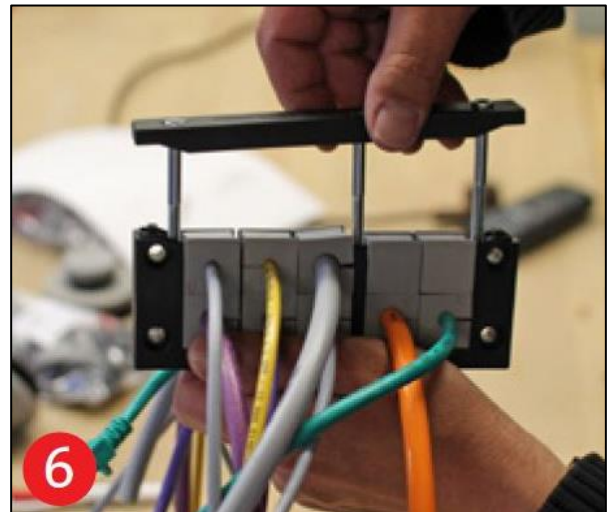

After completing the grommet placement set the cover strip on the frame again.

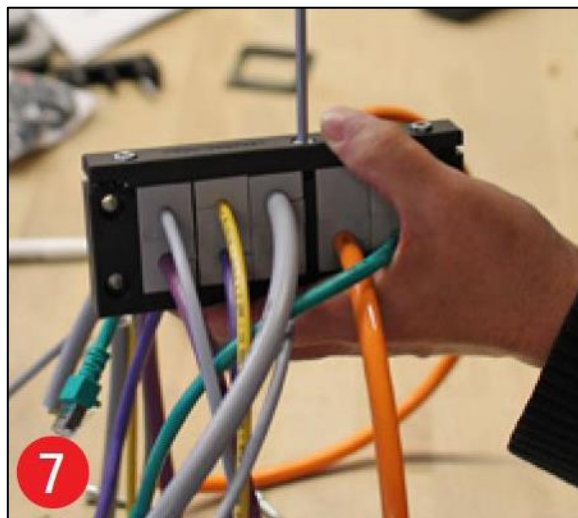

Now screw the frame and cover strip together.



Remove the foil off the one-sided self-adhesive gasket.



Tape the gasket around the control box entry point (should already be on the control box), if not already done simply snip the bottom or top of the gasket to fit the cables.

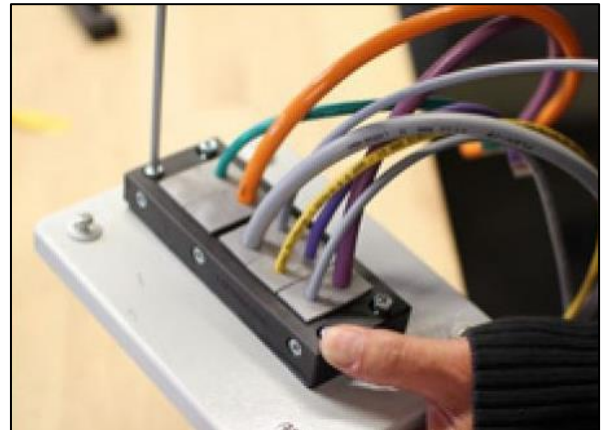

And screw the cable entry frame to the control box.