

ShopBot Vacuum Hold-down System

A vacuum hold-down system consists of the blower and associated plumbing. Then, depending on the type of vacuum system, it also includes a vacuum plenum and a bleeder / spoil board, or fixtures and templates. Before beginning the assembly of your vacuum system you should already have attached the support board on your table to the cross supports. See Assembly Manual.

Types of Vacuum Systems

There are two general strategies for the use of vacuum in holding parts for cutting or machining with a CNC router. You can either create seals around specific areas to be vacuum clamped in a "Conventional" manner, or you can draw air through a broad area of a permeable bleeder board to create a more "Universal" vacuum.

Conventional: The conventional solution is typically more affordable. It makes use of high vacuum (20-29"Hg) with a low flow volume. It works well for machining parts that are not cut out with through-cuts. It works well if you are cutting repetitive parts for which it is practical to first cut a vacuum template that maintains the vacuum seal, even when the part is through-cut. With these systems, small leaks will cause a large drop in vacuum, which is why the vacuum seal is so important to holding your parts securely. When using conventional techniques it is often adequate to use: a shop-vac, compressed air venturi vacuum, small blower or rotary vane blower to produce the vacuum. Conventional vacuum solutions tend to be specific to the application or production process and are usually devised by each shop. The plenum system, described below, could be used in conjunction with vacuum templates in a conventional system, even though it is designed for universal vacuum and bleeder board.

Universal: In contrast to conventional vacuum holding, universal systems have the advantage that you do not need specific sealed vacuum fixtures or templates. You can just put a piece of material down on your table, apply the vacuum and cut, assuming there is enough surface area for the vacuum to hold the material while the parts are cut. The universal system does not usually require a vacuum template. Material can be placed directly on a bleeder board and sufficient vacuum can be maintained as long as the required airflow does not exceed the specifications of the particular blower. However, the universal solution requires a lot of airflow and depends on relatively powerful and expensive industrial blowers/pumps (either displacement or regenerative type) that typically require 3-phase power. The installation instructions in the following portion of this document are for a universal system using either a positive displacement or regenerative blower.

Safety

During Installation: Ensure that the electrical power is off before making the electrical connections to your blower by using a Lock out / Tag out system. All electrical connections should be made by a **licensed electrician**.

During Use: Wear adequate hearing protection when the blower is in operation.

- Stay clear of blower inlets and outlets. The exhaust gets extremely hot. Contact with the hot exhaust pipe can cause burns.
- Do not use PVC components on the outlet of the blower as they might melt and cause a fire.
- If you must route your exhaust to another location use metal pipe and locate the pipe such that people will not come into contact with it.

Understanding the Input Plumbing

It is helpful to understand the purpose of the various components on the input plumbing of your blower. These components are already preassembled but knowing how they work can help you prolong the life of your blower. It is important to understand that the system has a *dirty side* and a *clean side* that is separated by the in-line filter. The plumbing from the in-line filter to the blower must remain clean and must contain a relief valve should the in-line filter become clogged.

There is a relief valve connected in the input plumbing and its purpose is to protect the blower from exceeding its maximum vacuum. The valve should be installed between the in-line filter and the blower as close to the intake as possible. There is an inlet filter on this relief valve to prevent debris from being ingested into the blower when the valve opens. If debris enters the blower it can cause premature failure. The arrow on the valve indicates the direction of airflow and should point toward the pipe that leads to the blower inlet. If the valve is mounted too far from the blower inlet or if the pipe is smaller than specified, then the valve may not open at the vacuum level that it was calibrated for, possibly resulting in a **catastrophic blower failure**. The valve is calibrated for your ShopBot vacuum table and no adjustment should be necessary. There is a vacuum gauge near the blower inlet so that you can monitor your systems performance.

Importantly, there is also an in-line filter positioned between the blower and your manifold. This filter prevents any debris from entering the blower through the plenum. It needs to be checked regularly and kept clean to allow your blower to work at full efficiency.

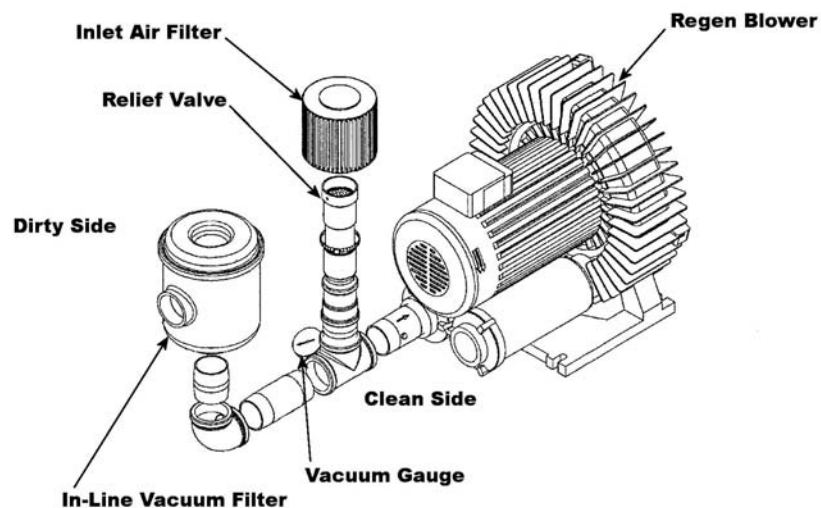

Figure 1 Regenerative blower and input plumbing.

Installing Your Blower

Read these instructions carefully. Improper installation will void the warranty.

We take every precaution to ensure that the blower you ordered is configured correctly and that all the components are installed, but please take a moment to verify a few things before proceeding with your installation.

- Check the electrical specifications on the plate of the blower and verify that the blower voltage matches your supply voltage. This voltage does not have to be exact but must be within the specified range (e.g. 208-230 volts). If you supply 460 volts to a blower that is wired for 230 volts you will burn up the motor and void the warranty. For both safety and warranty purposes, **have a licensed electrician make the electrical connections to your blower.**
- Make sure that the relief valve and filters are in place. **If debris is ingested into the blower, the blower will seize up.**
- Ensure that there is adequate airflow around your blower to allow for proper cooling. Taking a few minutes now can save you costly downtime and/or repair expense.
- Once the blower is wired, your electrician should check for proper rotation. If the rotation is not correct, switch any two of the 3 phase wires. A properly installed and maintained blower will give you years of trouble free service.

ShopBot cannot be liable for damages resulting from improper wiring or assembly. The blower manufacturer's warranty only covers defects in material or workmanship.

The Vacuum Plenum Board

1. You will be using a sheet of MDF for the vacuum plenum board. Attach the MDF board to the support board by counter sinking $\frac{1}{4}$ " screw holes around the border of the plenum. Space the screws about 16" apart. With the ShopBot plenum files you have about 2" between the edge of the material and the airflow channels. Use drywall screws to attach the plenum board to the support board within this area.
2. You are now ready to cut the plenum. You can use one of the basic plenum files that are included in the Control Software or you can create your own custom vacuum configuration. Use the ShopBot Part File Editor to view the instruction in the plenum file or click on the yellow exclamation point on the fill-in sheet for the plenum file to view the instructions.

Bit suggestions: $\frac{1}{2}$ " straight bit or 90 degree V-bit with a flat bottom. The choice of bits is partly dependent on the depth of cut. If you use a V-bit, make sure that the cut is not so deep that it cuts into the area that divides the zones. The plenum files included in the Control Software are designed to be cut with a $\frac{1}{2}$ " straight bit.

If you use one of the plenum files that is included in the Control Software, the cutting of your plenum board is pretty straight forward.

- Type FP and select the file that has the number of zones that you want and that matches the table size that you have. When hit OK to run the plenum file you will get a series of prompts. The first prompt will ask you if you are zeroed at the center of the plenum board. When you respond to this prompt with a Y the tool will begin cutting the channels in your plenum board.
- When the channels are finished you will get a prompt asking if the holes need to be relocated. Check to make sure that the holes clear the table cross supports and relocate the holes if necessary. Remember to include clearance for the flange when considering placement of the holes. You should also lay out the plumbing first to determine the best location for the holes. If the holes are in line with each other as in Figure 2, you may not be able to run your pipe in a straight line to your vacuum manifold; so check first. You might need to offset the holes to get the proper clearance. If you need to relocate the hole and answer Y to this prompt, the keypad will come up allowing you to use the arrow keys to reposition your cutter.

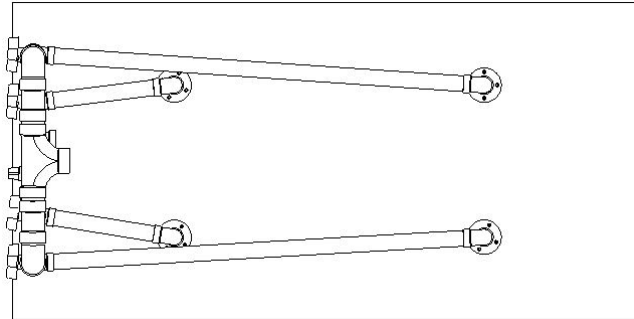

Figure 2 Bottom view of vacuum plenum plumbing

- Once you have the cutter centered where you want the hole to be drilled hit Esc to exit keypad mode and OK to drill the hole. Once the hole is drilled a prompt will ask if the hole cut all the way through. If it didn't and you answer N a second cut will be made .25" deeper.

NOTE: You cannot use a V-bit to make the vacuum holes.

- After the plenum file has been cut and the holes have been drilled, countersink screw holes in the areas that divide the zones and use drywall screws to pull the plenum board tight to the support board.
- Seal the top and sides of the plenum board with polyurethane. The MDF will soak up the polyurethane so apply it liberally.
- Surface: Use the *Tabletop Surfer* file in the ShopBot Control Software. Click on the tool icon at the bottom of the red position window and select the *Tabletop Surfer*. Fill in the values in the pop up Window and create your file. Once you save this file, you can run it anytime that you need to surface the table.
- Seal the plenum with several coats of polyurethane.

Attaching the Plumbing to Your Zones

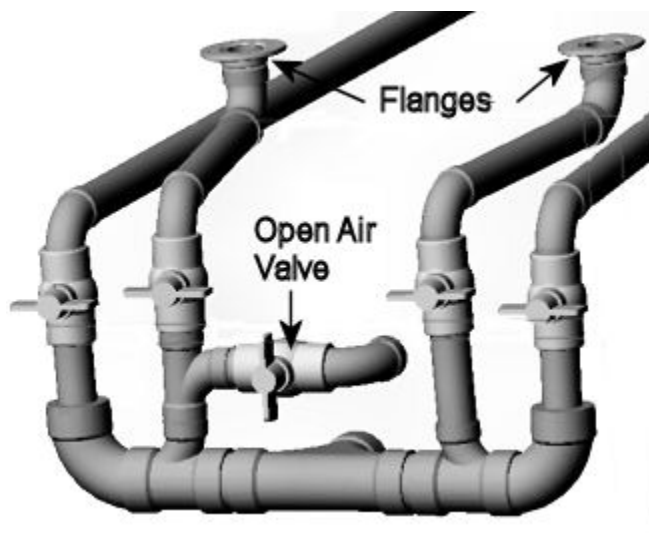

Figure 3 Manifold Valves

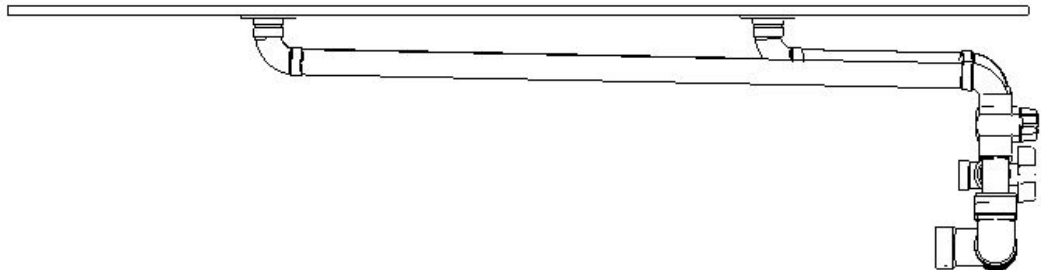

Figure 4 Side view of plumbing and plenum.

You can now attach the flanges to the holes that you drilled for each of your vacuum zones in the previous section. The flanges are screwed to the underside of the support board and connect the PVC pipes to the vacuum zones. The pipes from the zones will run to the vacuum manifold valves. These valves will allow you to cut off airflow from zones that you are not using. The large pipe from the manifold connects to the inlet filter. In addition to the zone valves there is an *open air* valve on the large pipe that leads to the filter. You should open this valve when you first start the blower and then close it once the blower is up to speed. Starting the blower under vacuum puts it under more stress.

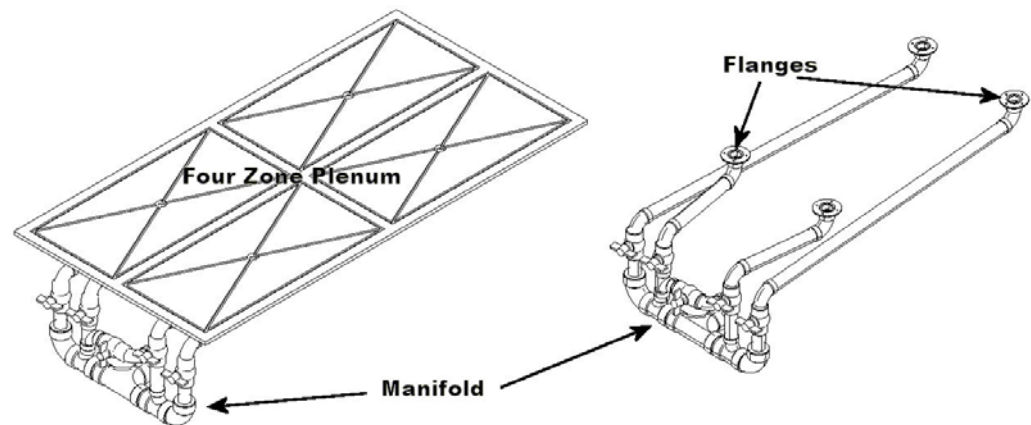

Figure 5 Vacuum plenum, manifold, flanges, and pipes

Attaching and Testing Your Bleeder Board

It is very important to prepare and evaluate your bleeder board properly. The lighter and more porous your bleeder board is, the more vacuum you will have left over to hold down your part. Ultra light density fiberboard (ULDF) is one of the best materials to use, although MDF and even particle board can be used in a pinch. One of the best brands of lightweight MDF is Trupan.

- First, place your bleeder board on the plenum and turn on the vacuum. It is a good idea to countersink a screw in each corner to prevent “potato chipping” of the board while it is being surfaced. Surface the first side to remove the slick outer surface and reduce the thickness of the MDF. Remove the bleeder board from the table when finished and clean up any debris and sawdust so that it does not get sucked into the system.
- Next, seal the edges of the board and between the zones with silicone caulk. If you do not seal the edge, you will leave an area of 1.5 sq. ft. wide open, reducing efficiency. Put the planed side of the bleeder board on the vacuum plenum being careful to position it carefully. Turn the vacuum on to pull the board down while the caulk firms up.
- Mark the areas along the edge and between zones where it is safe to put screws. Countersink holes and use sheetrock screws to attach the spoil board to the plenum.
- Now apply your vacuum with all zones open and read the vacuum gauge. Subtract this number from the maximum vacuum and this is what is left over to hold your part. A well prepared bleeder board will use between 2”-4” Hg.

If you add another vacuum gauge on the dirty side of the filter (anywhere between the filter and table) you can monitor your filter’s efficiency. Both gauges should read the same. Monitoring this gauge can let you know when it is time to change the filter.

If you exceed the rated flow of your system, the vacuum pressure will drop from its maximum rating. To reduce the amount of air flowing through your system, you can either block off zones by shutting off the PVC valve to the zone or block off an area physically with some scrap material. You might want to keep a couple of pieces of shower pan liner rolled up near your table. This heavy grey rubber can be found at home improvement stores and is wonderful for blocking off areas when cutting odd size boards.

Tips for Vacuum Efficiency and Long Life

Test your high vacuum by closing the open air valve and all PVC zone valves. The vacuum gauge on the clean air side of the filter should read the rated vacuum of the blower. Check all joints for leakage. You should hear the relief valve letting air in to protect the blower. If your blower is exceeding its rated vacuum turn it off immediately and correct the problem. Continued operation will result in catastrophic blower failure.

Your blower motor is put under the greatest stress when it is first started. In order to prolong the life of your blower do not restart the blower more than necessary. For instance, don’t turn the blower off automatically after cutting a file if you plan on cutting another file immediately after. Close the zone valves and open the open air valve in order to change out sheets of material. If there is a lag time between cutting files then you can turn the blower off, but try to limit starts to no more than four per hour.

Warranty

We use several different blowers for vacuum systems depending on the needs of the customer and the power available at the site. Blowers are warranted by the manufacturer. If you have a problem with your pump/blower, ShopBot will help to get it resolved. However, note that warranty replacement or repair is done through the manufacturer and depends on correct installation and use of the blower.